

MÉDIUM 2

Machinerie intégrée en partie basse

*Integrated machineroom
in low part of the shaft*

450/630 kg

APPAREILS COMPLETS
COMPLETE LIFTS

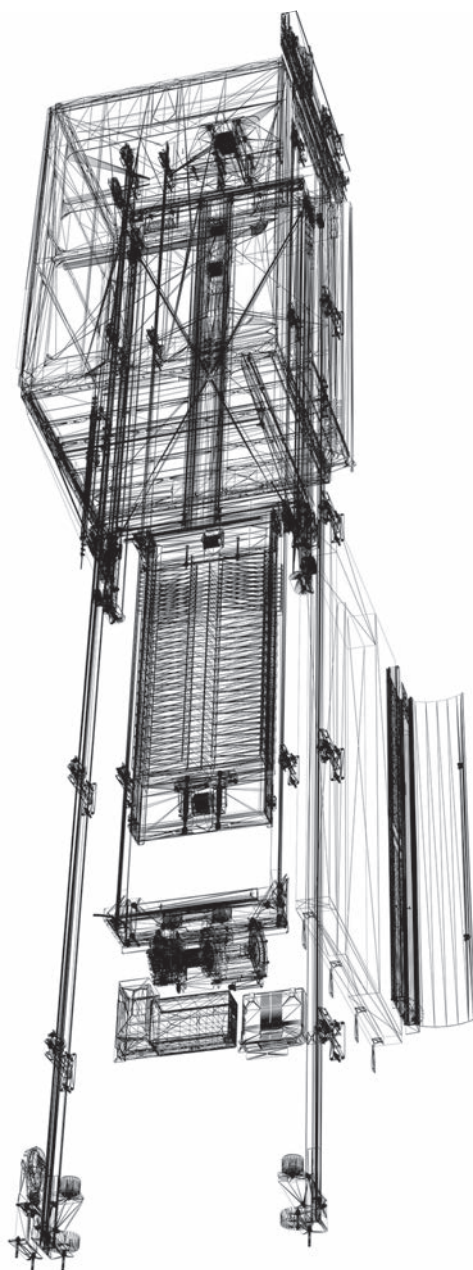

Bâtiment neuf / New building

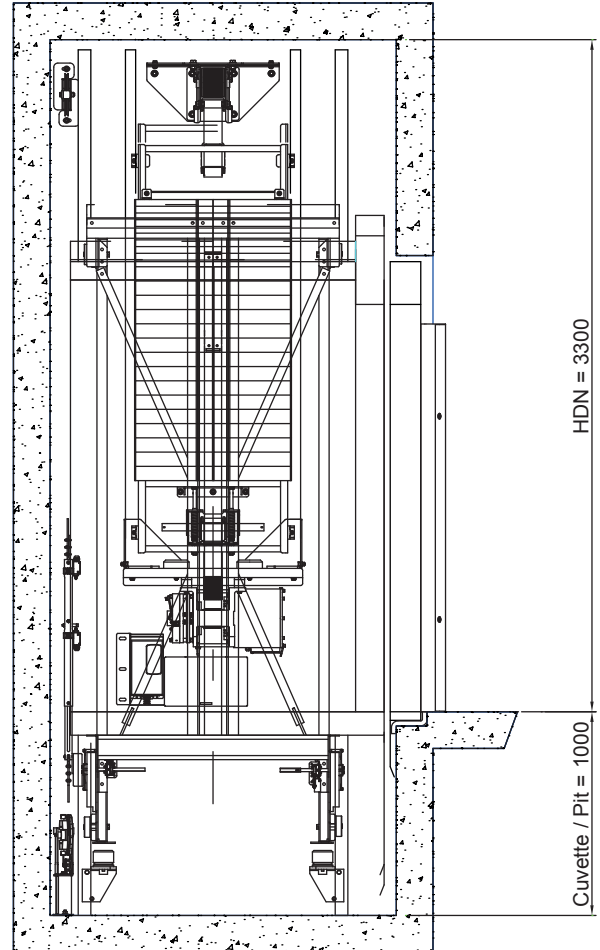
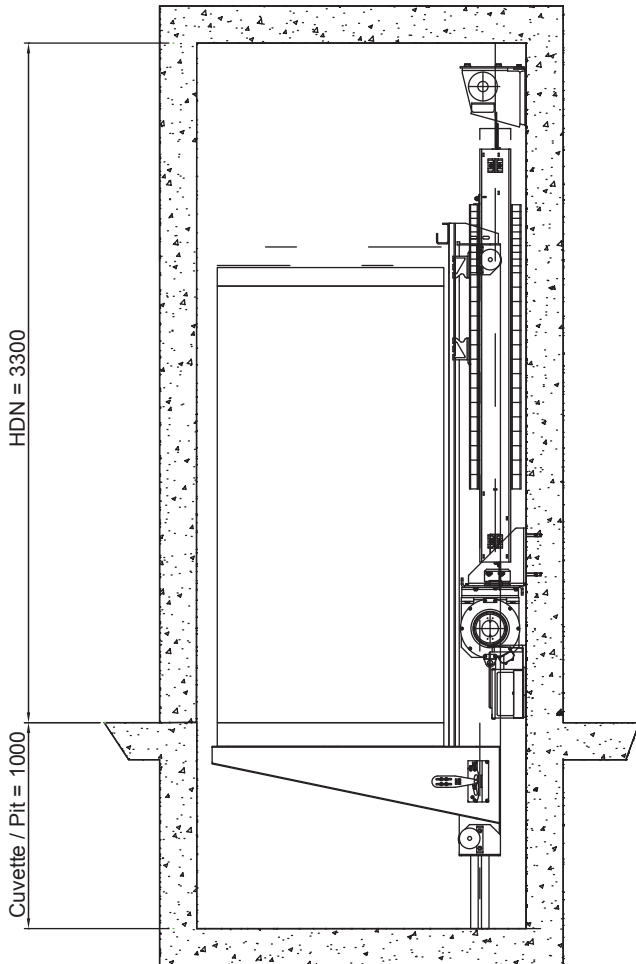

Caractéristiques générales / Main characteristics

Charge utile / Load	450 / 630 kg
Vitesse / Speed	1 m/s
Nb démarrages/heure / Startings per hour	120
Course / Rise maxi	18 m
Capacité / Capacity	6 / 8 personnes / 6 / 8 persons
Accès / Access	simple ou double / single or double
Surface cabine / Car area	1,31 / 1,66 m ²
Tension d'alimentation / Power supply	Triphasée 400 V + neutre / Three phase 400 V + neutral
Portes / Doors	Automatiques / Automatics

Configurations et dimensions possibles Configurations and dimensions available

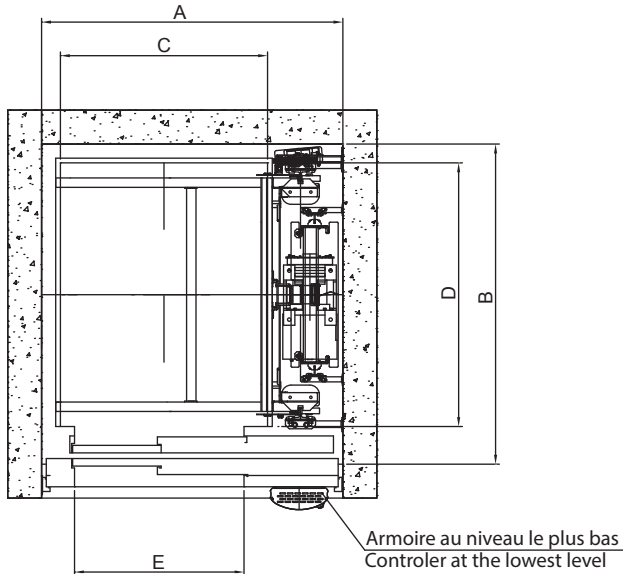

Simple accès / *Single access*

		450 kg	630 kg
		6	8
GAINE SHAFT	A	1500	1600
	B	1550	1700
CABINE CAR	C	1000	1100
	D	1250	1400
PASSAGE LIBRE CLEAR OPENING	E	800	800/900

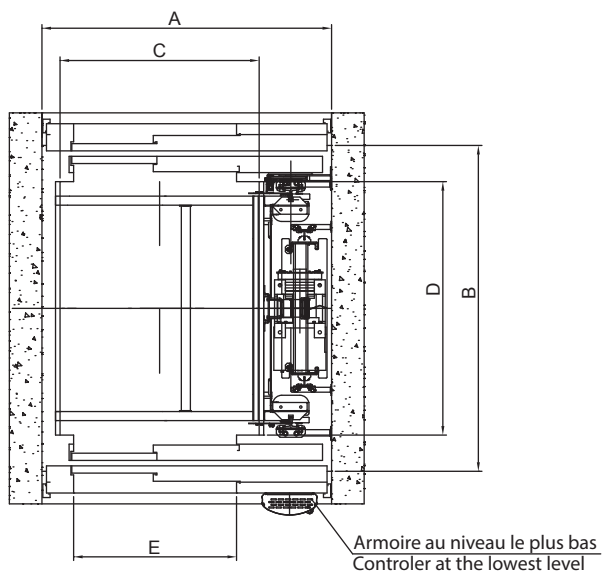

Double accès / *Double access*

		450 kg	630 kg
		6	8
GAINE SHAFT	A	1500	1600
	B	1650	1800
CABINE CAR	C	1000	1100
	D	1250	1400
PASSAGE LIBRE CLEAR OPENING	E	800	800/900

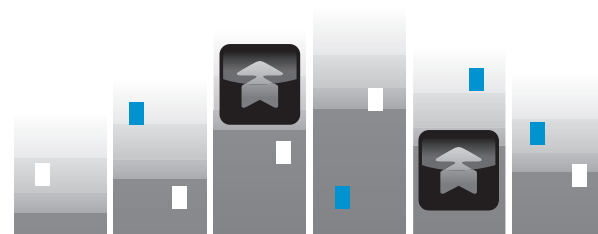

www.SODIMAS®.com



Siège social

11 rue Ampère
CS 9720

26603 Pont de l'Isère
FRANCE

☎ +33(0)4 75 84 86 00

✉ +33(0)4 75 84 67 30

e-mail : accueil@sodimas.fr



FABRICATION FRANCAISE
FRENCH MANUFACTURING



Création SODIMAS 09/2014 - Photos et illustrations non contractuelles. Sous réserve de modifications. Reproduction, même partielle, interdite.
SODIMAS design - Photographs and illustrations not contractual. Modifications without prior notice. Speechless reproduction even partial



Module H - Directive européenne 95/16/CE
Module H - European directive 95/16/EC